

PRODUCT BRIEF

Distressed Concrete

Pre-cast, lightweight concrete panels with an aged and weathered texture applied to walls, fireplaces and more. Suitable for non-combustible interior and exterior applications.

Recommended Sizes

Available in 5/8" (16mm) thickness in the following dimensions:

6" x 60" (152.4mm x 1524mm)

8" x 84" (203.2mm x 2133.4mm)

30" x 30" (762mm x 762mm)

24" x 36" (609.6mm x 914.4mm)

30" x 48" (762mm x 1219.2mm)

24" x 72" (609.6mm x 1828.8mm)

Made to order. Custom sizes available

Weight

6" x 60" Panel: 8.2kg (18.04 lbs)

8" x 84" Panel: 15.3kg (33.67 lbs)

30" x 30" Panel: 20.5kg (45.10 lbs)

24" x 36" Panel: 19.68kg (43.30 lbs)

30" x 48" Panel: 32.8kg (72.16 lbs)

24" x 72" Panel: 39.36kg (86.60 lbs)

Joint Options

Best suited to be installed with butt joints.

Prepared Substrate

The substrate should be smooth, plumb, level and stable prior to installation.

Adhesive

We recommend an instant grab MS Polymer adhesive such as Xcel IGA for both interior and exterior use.

Caulking

Colour matched and sanded. We recommend using MAPEI Keracaulk or TEC Accucolour.

Sealer

Concrete is a porous material, and most of our concrete products are sealed before shipping or installation unless discussed with the client. We use various sealers based on the concrete application.

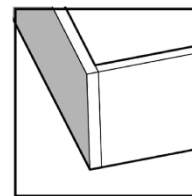
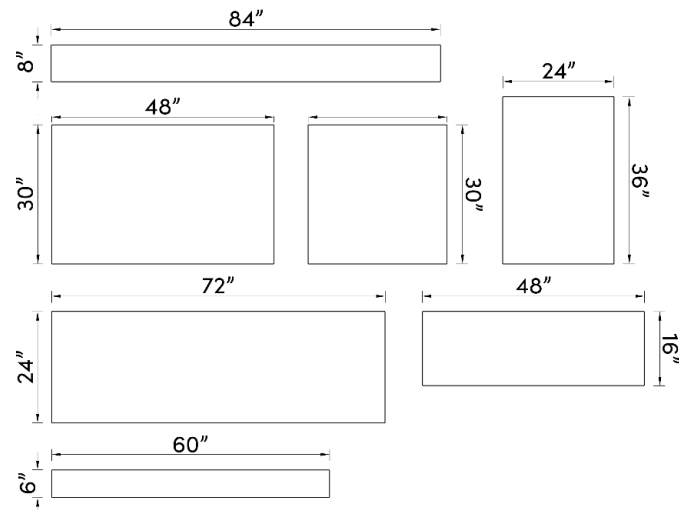

Butt Joint

